

OLMO

USER MANUAL



PALMARIA

INDEX

1.0 General warning	3
1.1 Important safety information	3
2.0 Etrotek system main features	4
2.1 How to switch on/off Etrotek system	4
3.0 Battery	5
3.1 Battery installation and removal	5
3.2 Battery key	6
3.3 Battery cleaning	6
3.4 How to charge the battery	6
4.0 Display	7
4.1 Display control panel	8
4.2 Main screens	8
4.3 Assistance levels	9
4.4 Walk mode	10
4.5 Settings	10
4.6 Error codes	11
4.7 Technical assistance	11
4.8 Cleaning and maintenance	11
4.9 Disposal	12

1.0 GENERAL WARNING

Please read all the warnings and information in this User Manual carefully before using the e-bike:

- Please contact the retailer for any information concerning the installation or adjustment of the e-bike that is not provided in this manual.
- This product must be disassembled or adjusted only by qualified personnel.
- This product must be used in compliance with the local laws and regulations.

WARNINGS: The use of batteries, battery chargers or other aftermarket accessories not approved by MONTANA S.R.L. may compromise the normal functioning of the system and may cause damage. Moreover, it voids the warranty.

1.1 IMPORTANT SAFETY INFORMATION

- Do not deform, modify or disassemble the battery. Do not weld anything directly on the battery. It may cause leaks, overheating, explosions or battery fire.
- Do not leave the battery next to heat sources such as heaters. Do not warm up the battery and do not throw it into the fire. This may cause explosions or battery fire.
- Do not immerse the battery into liquids such as water and do not wet the connectors. This may cause overheating, explosions or battery fire.
- Use only MONTANA S.R.L. approved battery charger to charge the battery, and respect the requirements indicated for battery charging. Not following these requirements may cause overheating, explosions or battery fire.
- Should any liquid leak from the battery and come into contact with your eyes, rinse the eyes with water without rubbing them and call your doctor. This may cause eye injury.
- Do not charge the battery in highly humid places or outdoors. This may cause electric shocks.
- Do not insert or remove the charging plug if it is wet. This may cause electric shocks. If there are traces of water on the charging plug, remove them before inserting it.
- If the battery is not fully charged after 6 hours, remove the plug from the socket and contact the retailer. Not following these requirements may cause overheating, explosions or battery fire.
- Do not use the battery when the temperature exceeds the range displayed below. This may cause battery fire, injuries or malfunction.
 1. Using the e-bike: -20 °C / +60 °C;
 2. During the battery charge: 0 °C / +45 °C.

General rule for a safety ride

To avoid accidents, do not pay excessive attention to the display when you are riding your e-bike.

WARNINGS:

Follow the instructions contained in this manual for a correct use of the e-bike:

- Regularly check the condition of the battery charger, in particular the wire, the plug and the case. If the battery charger or the adapter are broken, do not use the battery until they are fixed up.
- People (kids included) with reduced physical, mental or sensorial capabilities must not use the e-bike unless they have been instructed on how to use it by someone responsible for their safety and supervision.
- Kids must not play too close to the e-bike.
- Contact the retailer for the installation and adjustment of the e-bike.
- Do not put the e-bike upside down. This may cause damage to the display or to the shift lever.
- Use the e-bike with care without exposing it to excessive stress.

WARNINGS: Do not use high-pressured water or steam jets to clean the motor, the display or the battery as they may cause damages or malfunctioning. Do not use high-pressured air jet to dry the e-bike.

2.0 ETROTEK SYSTEM MAIN FEATURES

To use the ETROTEK propulsion system, make sure that the following requirements are met:

- The battery must be sufficiently charged.
- The speed sensor must be correctly connected and the magnet correctly positioned.

The motor automatically deactivates when the e-bike reaches the speed of 25 km/h.

The motor automatically reactivates when the user restarts to pedal and the speed is less than 25 km/h.

As the user stops pedaling, the motor automatically deactivates. The motor reactivates as the user restarts pedaling. The motor cooperates and harmonizes with the user's effort.

2.1 HOW TO SWITCH ON/OFF ETROTEK SYSTEM

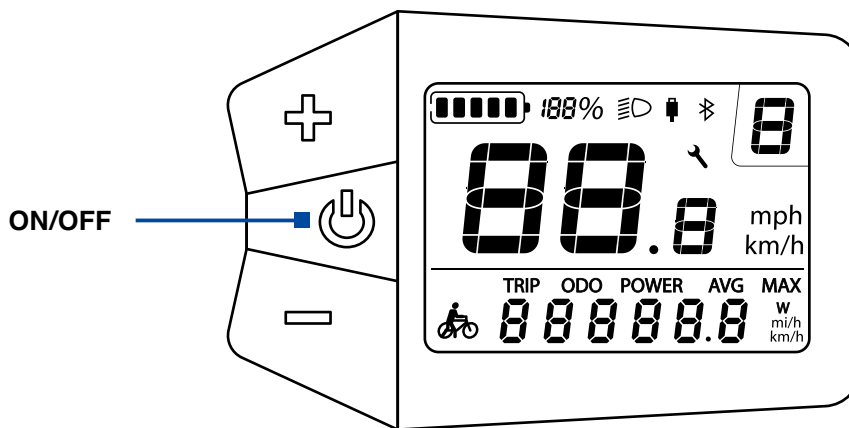

SWITCHING ON THE SYSTEM::

Press and hold the **ON/OFF** button for 3 seconds.

Wait a few seconds to allow the correct loading of the Home page.

SWITCHING OFF THE SYSTEM:

Press and hold the **ON/OFF** button for 1 second.

3.0 BATTERY

3.1 BATTERY INSTALLATION AND REMOVAL

WARNING: Always remember to switch off the battery before the battery installation or removal.

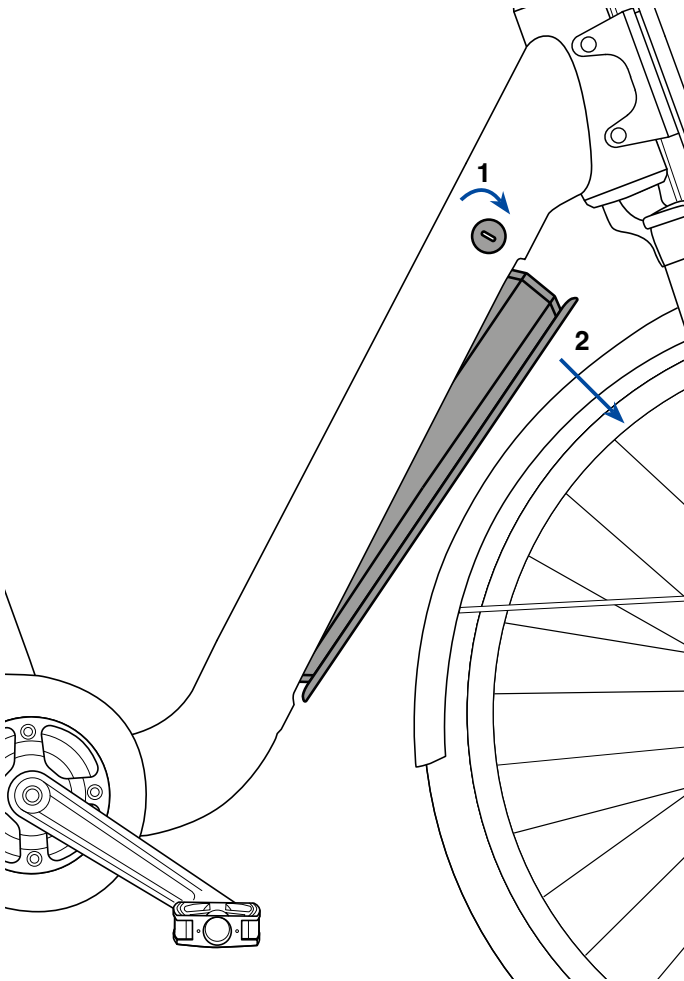

BATTERY REMOVAL

1. Insert the key into the lock and turn it clockwise to unlock the battery.
2. Grab the upper part of the battery and remove it from the support.

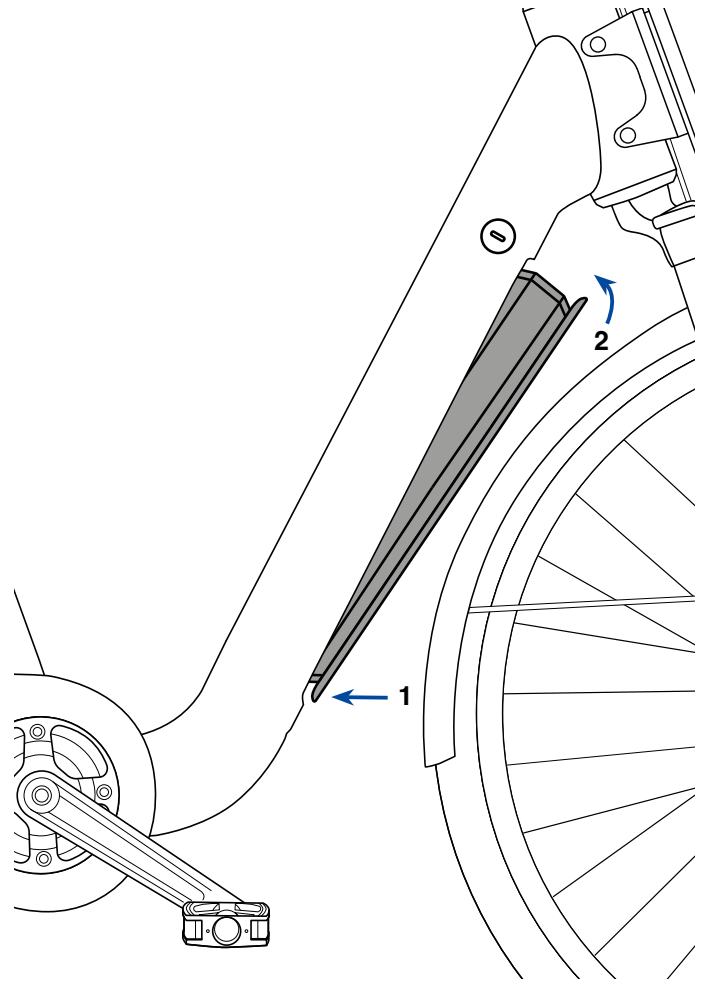

BATTERY INSTALLATION

1. Insert the lower part of the battery into the down tube opening paying attention to avoid ruining the rubber gaskets, and then connect the upper part to the electric connectors.
2. The “click” sound indicates that the battery is correctly locked. There is no need to insert the key to assemble the battery.
3. During this operation make sure to handle and assemble the battery with care to avoid damages to the electric components and connectors.
4. Remove the key from the lock and store it in a safe place.

!! DANGER: Do not use the e-bike with the key on. This may cause the battery to drop or the key to be lost.

WARNING:

- Before using the e-bike make sure that the battery is locked and that the charging socket cover is closed.
- Remove and store the battery in a dry place before transporting the e-bike; cover and protect the electric connectors from weather elements.

3.2 BATTERY KEY

In case of key loss, contact your retailer. He will replace the whole padlock.

3.3 BATTERY CLEANING

- Do not use diluents or solvents to clean the e-bike parts. Such products may damage the components.
- Use a damp cloth to clean the battery and plastic parts.
- The battery is designed to be completely waterproof and, when assembled, it can be used also in case of rain. Anyway, when it is not assembled on the e-bike, the battery must not enter into contact with water as in this case the connectors are not protected.
- Do not clean the battery with high-pressured jets. This may cause malfunctioning.
- Remove the battery before cleaning the e-bike.

3.4 HOW TO CHARGE THE BATTERY

- At the moment of the purchase the battery is not completely charged. Before using the e-bike it is necessary to charge the battery completely. If the battery runs out of charge, it will be necessary to charge it as soon as possible. If not, the battery lifetime will tend to reduce considerably.
- At the moment of storing the e-bike for a prolonged period of time, the battery charge must be around the 70% of its total capacity. Moreover, it is recommended to charge the battery for around 2 hours each 3 months to avoid the complete battery discharge.

HOW TO CHARGE THE BATTERY WHEN DISASSEMBLED

1. Insert the battery charger plug into the socket.
2. Insert the battery charger adapter into the battery socket. Leave the battery on a flat surface during the charging.

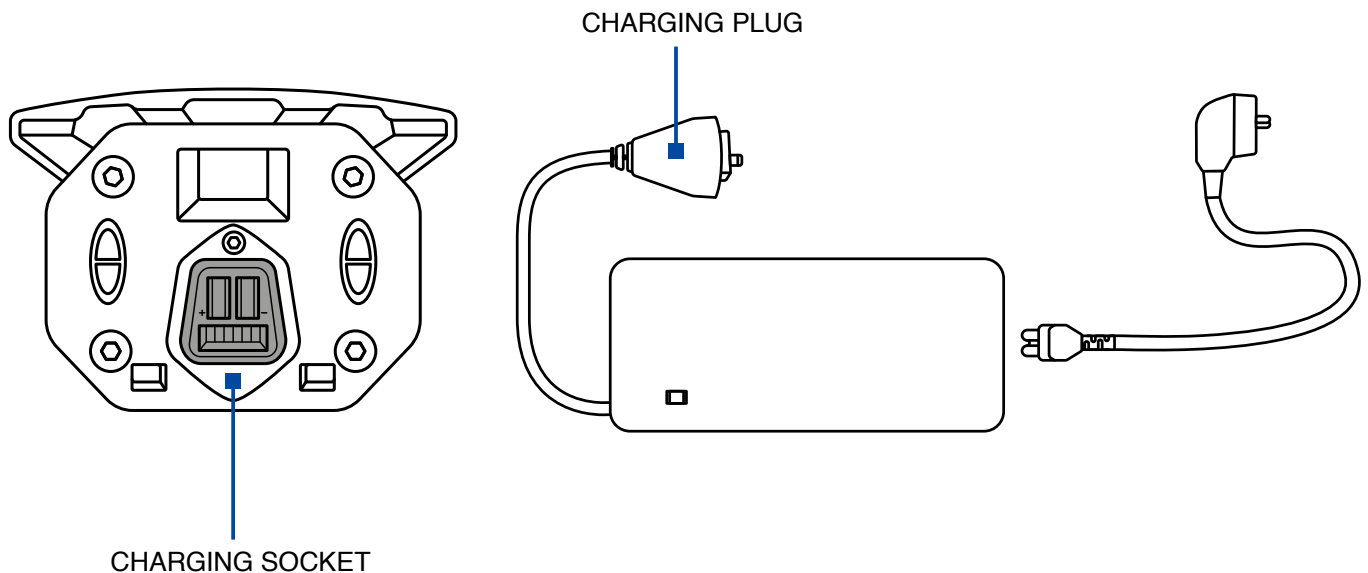

HOW TO CHARGE THE BATTERY INSTALLED ON THE FRAME

1. Switch off the system.
2. Secure the e-bike to avoid any fall during the battery charge.
3. Insert the battery charger power plug into the socket.
4. Insert the battery charger adapter into the frame socket.

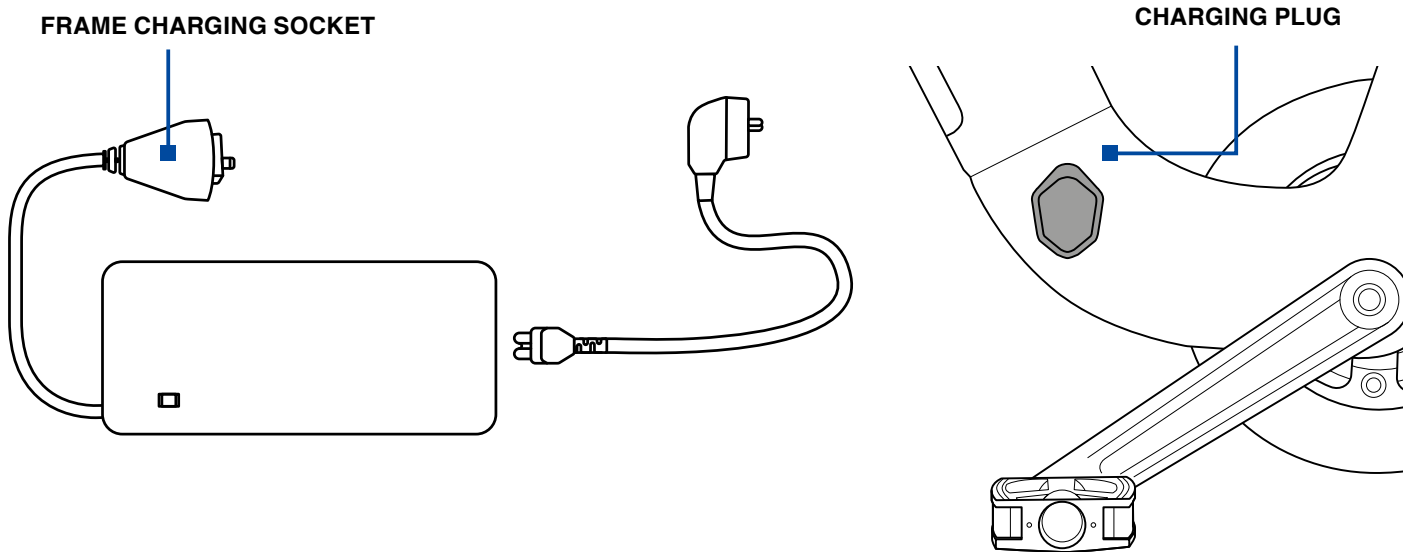

WARNING:

- Follow the safety rules contained in this manual during the battery charge.
- Check and remove any trace of dirt from the battery charge connectors and sockets.
- A possible interruption during the battery charge won't cause damages to the battery.
- If the battery is charged when the battery is assembled on the e-bike, close the frame charging socket cover after each charge.

4.0 DISPLAY

WARNINGS: Using the display during the ride may distract the user and cause accidents. Always follow the traffic regulations.

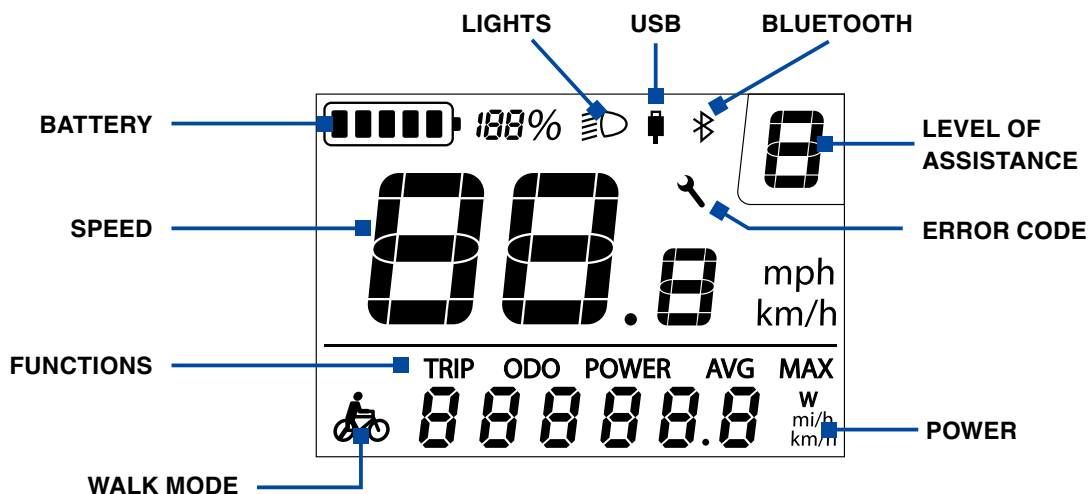

4.1 DISPLAY CONTROL PANEL

The display is provided with 3 buttons that allow the user to navigate within the software. They can be used either with a short pressing or a prolonged pressing (more than 2 seconds).

BUTTON	SHORT PRESSING (< 1 SEC)	LONG PRESSING (> 2 SEC)
ON/OFF	Allows the user to switch from one main screen to the other; allows to confirm a selection during the settings modifications.	Allows to switch the system on or off.
+	Allows the user to increase the assistance level; allows to move within the options in the settings menu.	Allows to turn on or off the e-bike lights.
-	Allows the user to decrease the assistance level; allows to move within the options in the settings menu.	Allows to enter the Walk mode.
+ and -	-	Allows to enter the Settings menu

4.2 MAIN SCREENS

After switching on the system, the first screen is TRIP on the Home section. The Home section is composed by 6 screens.

Press the **ON/OFF** button to switch from one screen to the other.

From any Home screen it is always possible to:

- Adjust the level of assistance (pressing the + or – buttons);
- Enter the WALK mode (pressing and holding the – button);
- Turn on or off the e-bike lights (pressing and holding the + button);
- Enter the Settings menu (pressing and holding the + and – buttons).

SCREENS MAIN INFORMATION

Each screen provides different information, except for the following data always displayed:

- Battery charge percentage;
- E-bike lights status;
- Level of assistance;
- Current e-bike speed (in km/h).

SCREEN 1 – TRIP

In addition to the information listed above, this screen displays the distance travelled (in kilometers) from the last reset.

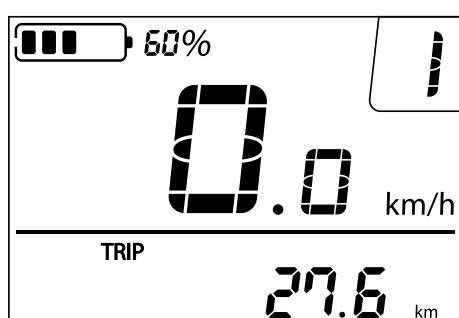

SCREEN 2 – ODO

This screen displays the total distance travelled (in kilometers) with the e-bike. This value cannot be reset.

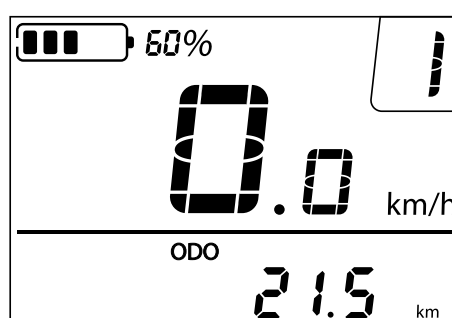

SCREEN 3 – TRAVEL TIME

This screen displays the travel time (expressed in hours:minutes) from the last reset.

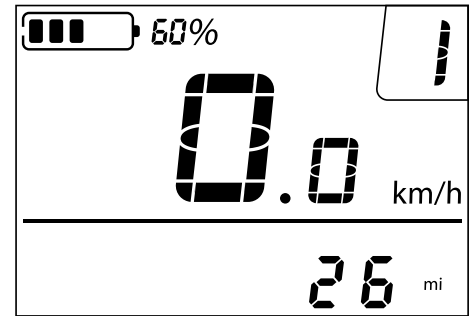

SCREEN 4 – POWER

This screen displays the power generated by the motor in Watts (W).

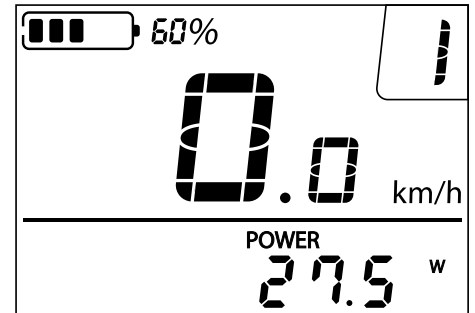

SCREEN 5 – AVERAGE SPEED

This screen displays the average speed (in km/h).

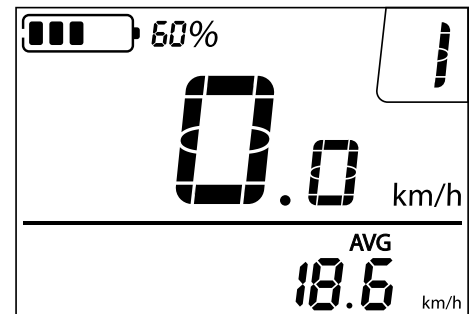

SCREEN 6 – MAXIMUM SPEED

This screen displays the maximum speed achieved during the ride expressed in km/h.

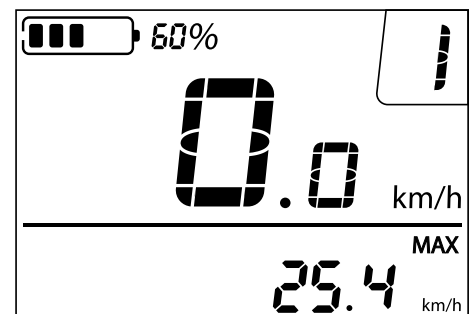

4.3 ASSISTANCE LEVELS

It is possible to adjust the level of assistance from any Home screen, pressing the + or – button. The system is set on the level of assistance 1 by default.

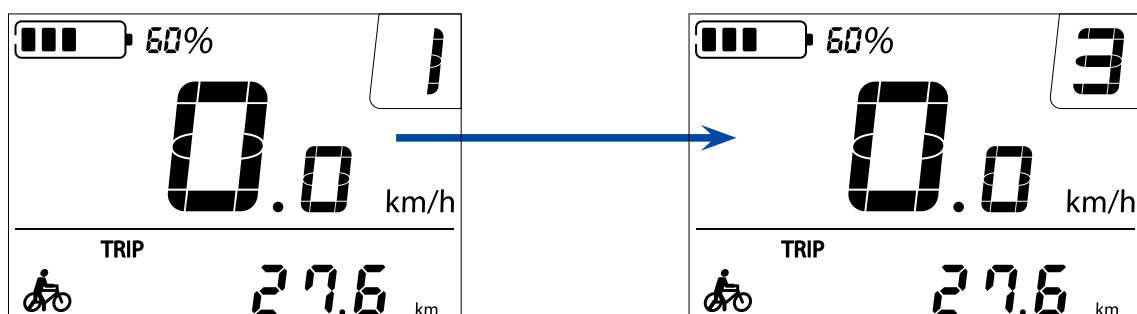

4.4 WALK MODE

The system is provided with a function that allows to activate the motor up to a speed of 6 km/h without pedaling.

Press and hold the – button to enter the Walk mode.

The motor will enter the Walk mode and the related icon will be displayed on the screen.

Release the – button to exit the Walk mode.

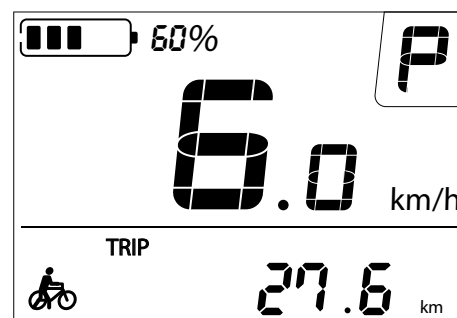

The system will automatically exit the walk mode in the following cases:

- The user releases the – button;
- The speed is over 6 km/h;
- The rear wheel is blocked.

4.5 SETTINGS

It is possible to enter the setting menu from any Home screen by pressing and holding the buttons + and – for 2 seconds.

TRIP RESET

This function allows to reset all the data related to the travelled distance (although the total distance travelled by the e-bike – ODO – cannot be reset).

Press the + or – button to select the **Y** (yes) or **N** (no) option.

The default option is N.

Press the **ON/OFF** button to save the selected option and to move to the next settings.

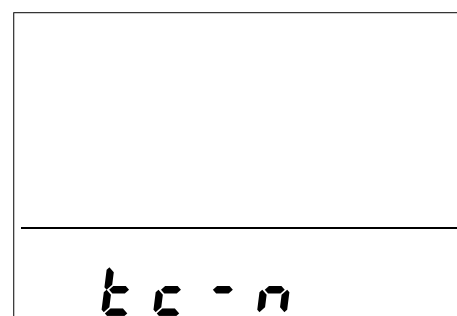

DISPLAY BRIGHTNESS

This voice allows to adjust the brightness of the display.

Press the + or – button to increase or decrease the brightness; it is possible to select a value between 1 and 3. The system default value is 2. Press the **ON/OFF** button to save the selected option and move to the next settings.

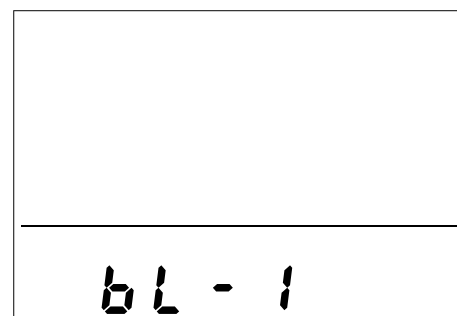

UNIT OF MEASUREMENT

This setting allows to choose the measure unit between kilometers per hour (km/h) and miles per hour (mph). Select 1 to set miles per hour or select 2 for kilometers per hour.

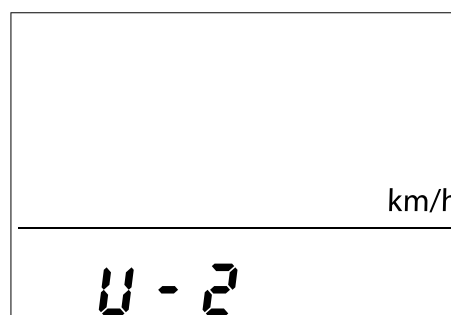
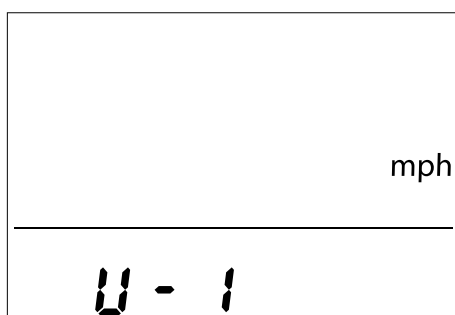

4.6 ERROR CODES

When the system detects an error, the related error code and icons  are displayed on the screen.

The table below lists the possible malfunctions and their related error codes:

ERRORE	PROBLEMA
21	The system has detected a problem with the voltage.
22	The system has detected a problem with the speed sensor.
23	Torque sensor signal not detected.
24	The system has detected a communication problem with the motor cable.
30	The system has detected a communication problem between the display and the controller.
31	The system has short-circuited.
32	The ON/OFF button is blocked.
33	The – button is blocked.
34	The system has detected an overvoltage.

4.7 TECHNICAL ASSISTANCE

In case of error codes, problems not previously listed or for any kind of system assistance (battery, motor and controller), contact the authorized retailer.

WARNINGS:

The manufacturer declines any responsibility for the damages caused to people or things and for possible malfunctioning in case of:

- Wrong use of the e-bike.
- Incompetence, carelessness, negligence or any kind of use that is not compliant with the instructions provided in this manual.
- Use of aftermarket parts not approved by MONTANA S.R.L.

4.8 CLEANING AND MAINTENANCE

Do not immerse the components into water and do not clean them with high-pressure jets of any kind.

WARNINGS: Do not use aggressive products, abrasive powder, acid or basic chemical solutions.

The manufacturer declines any responsibility for damages caused by a wrong cleaning or by the use of inappropriate products.

4.9 DISPOSAL

The disposal of the display, accessories and packaging must comply with the environmental regulations. Before proceeding to the e-bike disposal it is necessary to separate the plastic material from the electrical components, which must be sent to an authorized recycling center as established by the environmental regulations.

Separate the metallic parts for a correct recycling. The disposal of electrical and electronic components indicated by the specific mark must be done by authorized recycling centers.

The illegal disposal of Waste from Electrical and Electronic Equipment (WEEE) is punished with sanctions regulated by the related current laws.

Do not throw the components into the domestic waste. Do not throw this manual into fire.

WARNINGS: The disposal must be done by qualified personnel.

MONTANA S.R.L.

Il Marchio Olmo è prodotto e distribuito da Montana Srl

Via Domenico Rossi 70, 12060 Magliano Alpi (CN) - Italy

Tel. +39 017466828 - Fax +39 017466651

olmo@olmo-bike.it - www.olmo-bike.it